



Use & Care

G U I D E

27" Electric and Gas Dryers

A Note to You	2
Dryer Safety	3-4
Parts and Features ...	5
Checking Your Vent ...	6
Operating Your Dryer	8
Caring for Your Dryer	14
Troubleshooting	17
Requesting Assistance or Service	19
Index	23
Warranty	24

1-800-253-1301

Call us with questions or comments.



Making Your World
A Little Easier.™

www.whirlpool.com

PART NO. 3406077

A NOTE TO YOU

Thank you for buying a WHIRLPOOL® appliance.

Because your life is getting busier and more complicated, WHIRLPOOL appliances are easy to use, save time, and help you manage your home better. To ensure that you enjoy years of trouble-free operation, we developed this Use and Care Guide. It is full of valuable information about how to operate and maintain your appliance properly and safely. Please read it carefully.

Also, complete and mail the **Ownership Registration Card** provided with your appliance. The card helps us notify you about any new information on your appliance.

Please record your model's information.

Whenever you call to request service for your appliance, you need to know your complete model number and serial number. You can find this information on the model and serial number label/plate (see the diagram on page 5 for the location of the label). Also, record the other information shown in the next column.

Model Number _____

Serial Number _____

Purchase Date _____

Dealer Name _____

Dealer Address _____

Dealer Phone _____

Keep this book and the sales slip together in a safe place for future reference.

Our Consumer Assistance Center number is toll free.

1-800-253-1301

To find detailed product information, the location of the nearest Whirlpool dealer or authorized servicer, to purchase an accessory item, or register your appliance on-line, please visit our Web site at www.whirlpool.com

DRYER SAFETY

Your safety and the safety of others is very important.

We have provided many important safety messages in this manual and on your appliance. Always read and obey all safety messages.



This is the safety alert symbol.

This symbol alerts you to hazards that can kill or hurt you and others.

All safety messages will be preceded by the safety alert symbol and the word "DANGER" or "WARNING." These words mean:

⚠ DANGER

You **will** be killed or seriously injured if you don't follow instructions.

⚠ WARNING

You **can** be killed or seriously injured if you don't follow instructions.

All safety messages will identify the hazard, tell you how to reduce the chance of injury, and tell you what can happen if the instructions are not followed.

WARNING: For your safety the information in this manual must be followed to minimize the risk of fire or explosion or to prevent property damage, personal injury or death.

- Do not store or use gasoline or other flammable vapors and liquids in the vicinity of this or any other appliance.
- **WHAT TO DO IF YOU SMELL GAS**
 - Do not try to light any appliance.
 - Do not touch any electrical switch; do not use any phone in your building.
 - Clear the room, building or area of all occupants.
 - Immediately call your gas supplier from a neighbor's phone. Follow the gas supplier's instructions.
 - If you cannot reach your gas supplier, call the fire department.
- Installation and service must be performed by a qualified installer, service agency or the gas supplier.

continued on next page

IMPORTANT SAFETY INSTRUCTIONS

WARNING – To reduce the risk of fire, electric shock, or injury to persons when using the dryer, follow basic precautions, including the following:

- Read all instructions before using the dryer.
- Do not dry articles that have been previously cleaned in, washed in, soaked in, or spotted with gasoline, dry-cleaning solvents, other flammable, or explosive substances as they give off vapors that could ignite or explode.
- Do not allow children to play on or in the dryer. Close supervision of children is necessary when the dryer is used near children.
- Before the dryer is removed from service or discarded, remove the door to the drying compartment.
- Do not reach into the dryer if the drum is moving.
- Do not install or store the dryer where it will be exposed to the weather.
- Do not tamper with controls.
- Do not repair or replace any part of the dryer or attempt any servicing unless specifically recommended in this Use and Care Guide or in published user-repair instructions that you understand and have the skills to carry out.
- Do not use fabric softeners or products to eliminate static unless recommended by the manufacturer of the fabric softener or product.
- Do not use heat to dry articles containing foam rubber or similarly textured rubber-like materials.
- Clean lint screen before or after each load.
- Keep area around the exhaust opening and adjacent surrounding areas free from the accumulation of lint, dust, and dirt.
- The interior of the dryer and exhaust vent should be cleaned periodically by qualified service personnel.
- See Installation Instructions for grounding requirements.

– SAVE THESE INSTRUCTIONS –

PARTS AND FEATURES

The parts and features of your dryer are illustrated on this page. Become familiar with all parts and features before using your dryer. Page references are included next to some features. Refer to those pages for more information about the features.

NOTE: The drawings in this book may vary from your dryer model. They are designed to show the different features of all models covered by this book. Your model may not include all features.

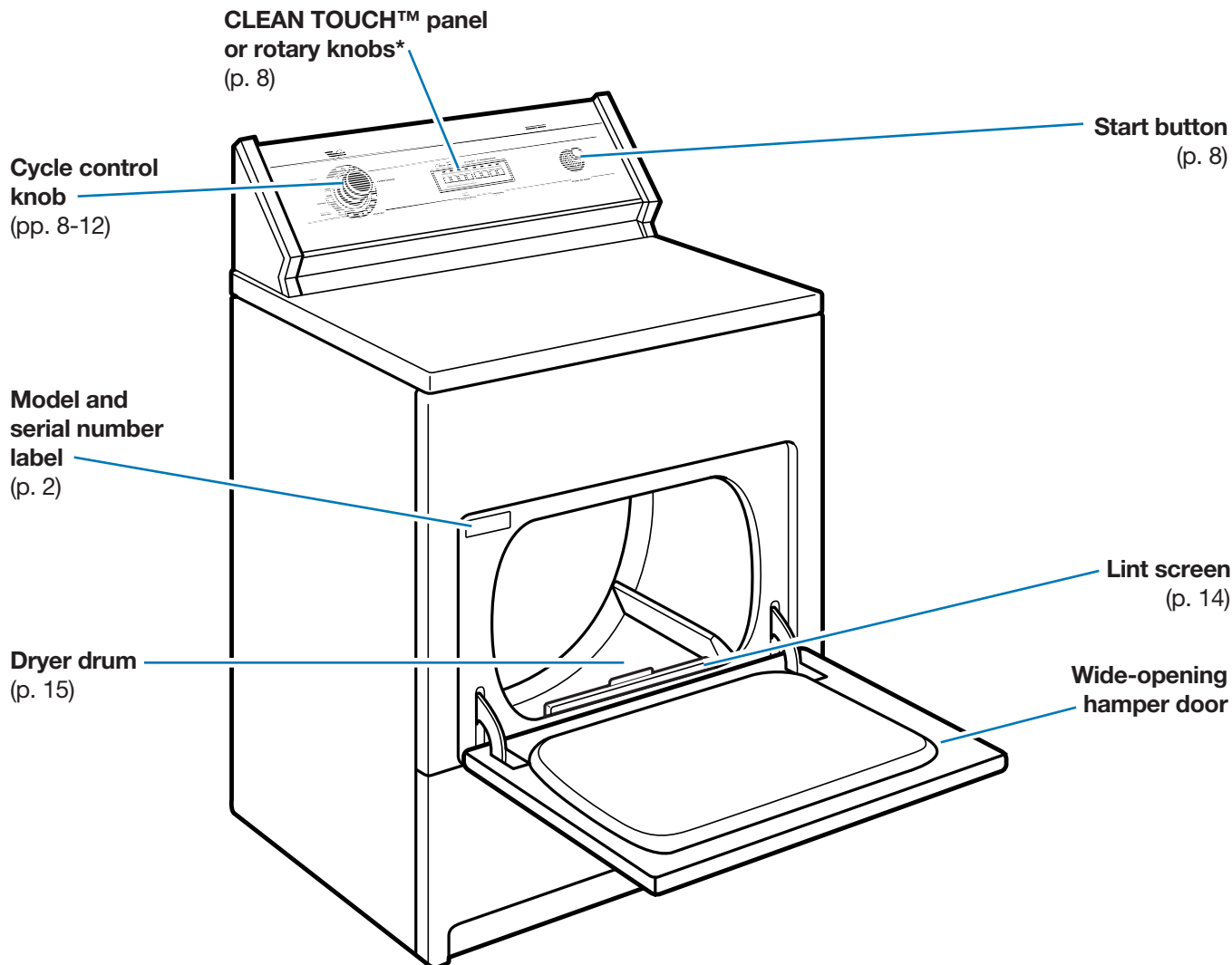

Additional features your dryer may have:

End of cycle signal selector (p. 9)

FINISH GUARD® feature selector* (p. 8)

Drying rack* (p. 13)

Drum light (p. 16)

* On some models

CHECKING YOUR VENT

Your dryer must be properly installed and vented to achieve maximum drying efficiency and shorten drying times. Use the minimum recommended installation clearances (found in your Installation Instructions) to avoid blocking the flow of combustion and ventilation air. Install your dryer in a well-ventilated room where the temperature is always above 45°F (7°C). Also make sure that your dryer is leveled. Refer to your Installation Instructions for more information.

VENTING

⚠ **WARNING**



Fire Hazard

Use a heavy metal vent.

Do not use a plastic vent.

Do not use a metal foil vent.

Failure to follow these instructions can result in death or fire.

If the dryer is not properly installed and vented, it will not be covered under the warranty.

NOTE: Service calls caused by improper venting will be paid for by the customer, whether it was a paid installation or self-installed. For paid installation, call the company that installed the vent for adjustment.

1. Do not use plastic vent or flexible metal foil vent.

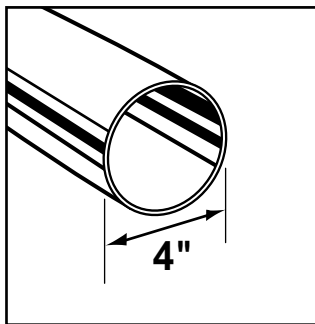

length requirements of vent.

Use 4-inch heavy metal or flexible metal vent. Do not kink or crush flexible metal vent. It must be completely extended to allow adequate exhaust air to flow. Check vent after installation. Refer to your Installation Instructions for proper

2. Use a 4-inch exhaust hood. Smaller hoods increase drying times.

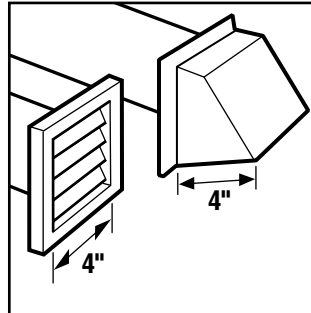

3. You can exhaust from the rear, left, right, or bottom of the dryer.

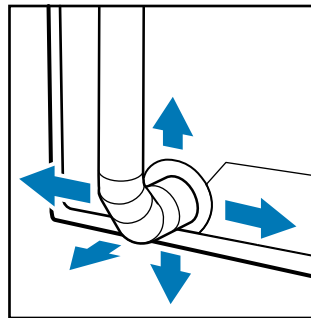

Space requirements are listed in your Installation Instructions.

Exhaust from the rear of the dryer: The exhaust vent can be routed up, down, left, right, or straight out the back of the dryer.

Exhaust from left, right, or bottom of dryer: To convert the dryer for exhaust out the right or left side, or through the bottom, you must use one of the following kits:

- Exhaust Kit No. 279818 (white)
- Exhaust Kit No. 279819 (almond)
- Exhaust Kit No. 279820 (ebony)

An exhaust kit can be ordered by calling **1-800-442-9991** and following the instructions and telephone prompts you hear.

VENTING (CONT.)

4. Use the straightest path possible when routing the exhaust vent. Avoid 90° turns, if possible. Allow room when using elbows or making turns. Bend vent gradually to avoid kinking.

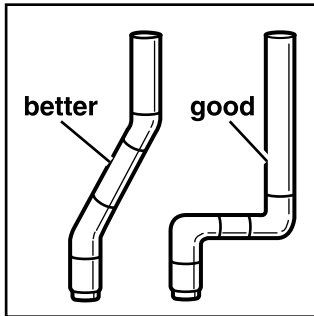

5. Use duct tape to seal all joints. **Do not** use screws to secure vent. Lint may catch on screws.

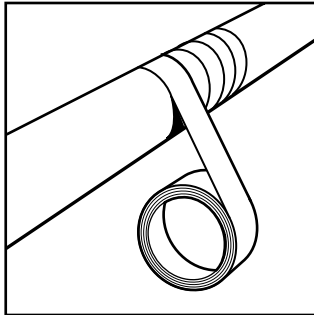

6. Clean exhaust vent periodically, depending on use, but at least every 2 years, or when installing your dryer in a new location.

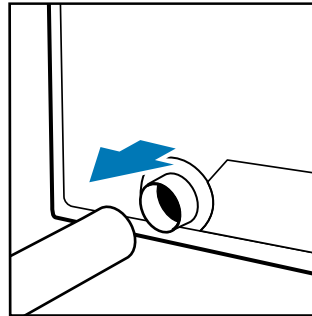

● Disconnect vent from the dryer and clean one section at a time until you reach the exhaust hood.

● Use the hose attachment on your vacuum, or a pole or wire with a

feather duster or rag attached, to clean out lint.

- Be sure the flapper on the outside end of vent moves freely.
- When cleaning is complete, be sure to follow the Installation Instructions supplied with your dryer for final product check.

OPERATING YOUR DRYER

To get the best dryer results possible, you must use your dryer correctly. This section tells you how to use your dryer properly and efficiently.

STARTING YOUR DRYER

⚠ WARNING



Explosion Hazard

Keep flammable materials and vapors, such as gasoline, away from dryer.

Do not dry anything that has ever had anything flammable on it (even after washing).

Failure to follow these instructions can result in death, explosion, or fire.

⚠ WARNING



Fire Hazard

No washer can completely remove oil.

Do not dry anything that has ever had any type of oil on it (including cooking oils).

Items containing foam, rubber, or plastic must be dried on a clothesline or by using an Air Cycle.

Failure to follow these instructions can result in death or fire.

Before using your dryer, wipe the dryer drum with a damp cloth to remove dust from storing and shipping. If your dryer has a Features Guide, remove it and place it with this Use and Care Guide.

1. Load clothes loosely into the dryer and close the door. Do not pack the dryer; allow space for clothes to tumble freely.



2. Turn the Cycle Control knob to the recommended cycle for the type of load being dried, as described in "Cycle descriptions" later in this section.

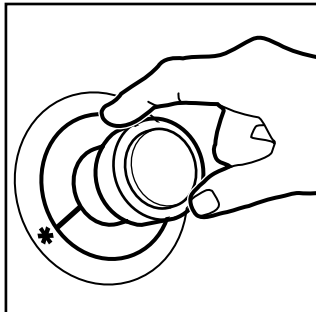

- Use the Energy Preferred Automatic Setting (*) to dry most loads.

NOTE: On some models, the Temperature selector is part of the Cycle Control knob.

3. If your dryer has a Temperature selector, set it to the recommended setting for the type of fabric being dried. The cycle descriptions on the following pages include temperature setting suggestions.
4. (OPTIONAL STEP) Some dryers have an On/Off FINISH GUARD® selector. The FINISH GUARD feature protects your clothes from wrinkling when you do not remove them from the dryer as soon as it stops.

- Set the FINISH GUARD selector to On to tumble the load without heat every few minutes up to 45 minutes after the drying cycle ends.
- A signal will sound every few minutes while FINISH GUARD is running if the Cycle Signal (End of Cycle Signal) feature is set to On. On some models, this signal is fixed and cannot be turned off. The signal and cycle end when you open the dryer door.
- Set the FINISH GUARD selector to Off if you do not want to run this feature.

NOTE: Some dryers have a FINISH GUARD feature that cannot be turned On or Off. See "Cycle descriptions" later in this section.

STARTING YOUR DRYER (CONT.)

5. (OPTIONAL STEP) If your dryer has a Cycle Signal (End of Cycle Signal) selector, set the selector to On if you want the dryer to sound a signal when a cycle is finished.

- The signal is helpful when you are drying permanent press, synthetics, and other items that should be removed from the dryer as soon as it stops.
- On some models, the End of Cycle Signal is part of the Start button.

6. Push the Start button.

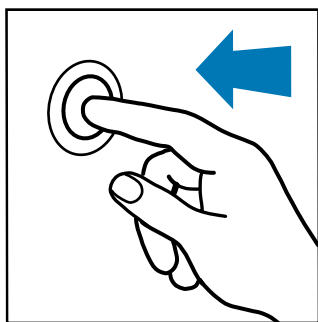

NOTE: Your dryer stops automatically when a cycle ends.

Stopping and restarting your dryer

You can stop your dryer anytime during a cycle.

To stop your dryer:

Open the dryer door or turn the Cycle Control knob to Off.

NOTE: The Cycle Control knob should point to an Off area when the dryer is not in use.

To restart your dryer:

Close the door, select a new cycle and temperature (if desired), and push the Start button.

SELECTING THE RIGHT CYCLE AND TEMPERATURE SETTING

The following pages describe the drying cycles on your dryer. The descriptions include suggested temperature settings and drying times for various loads.

Cycle and temperature tips

- Make sure you have selected the correct cycle and temperature for your load.
- Dry most loads using the Energy Preferred Automatic Setting (*).
- Use the Fluff Air cycle, or line dry rubber, plastic, delicate, and heat-sensitive fabrics.
- If some types of loads in the cycle descriptions on the following pages have more than one suggested temperature setting, choose the lowest setting available on your dryer.
- The last few minutes of all cycles are without heat to make the load cooler to handle.

Drying tips

- Always follow care label directions when they are available.
- If you use fabric softener sheets, always use softener sheets that are labeled as dryer safe and follow package instructions carefully.
- Remove the load from the dryer as soon as tumbling stops to reduce wrinkling. This is especially important for permanent press, knits, and synthetic fabrics.

LOADING

Loading suggestions

The chart below provides some guidelines on various types of drying loads. Load clothes loosely into the dryer. Do not pack the dryer; allow space for clothes to tumble freely.

Heavy Work Clothes	Delicates	Towels	Mixed Load
3 pair pants	3 camisoles	10 bath towels	3 double sheets
3 shirts	1 quilted robe	10 hand towels	4 pillowcases
4 pair jeans	4 slips	14 wash cloths	8 T-shirts
1 coverall	4 panties	1 bath mat	6 pair shorts
1 overall	2 bras		2 shirts
	2 nighties		2 blouses
	1 baby's dress		8 handkerchiefs

CYCLE DESCRIPTIONS

Automatic cycle(s)

Use an Automatic cycle to dry most loads.

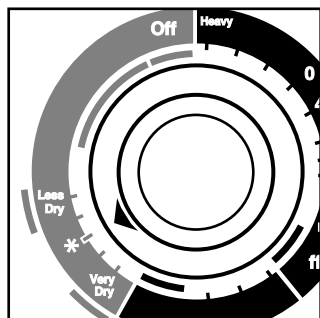

Depending on your model, the Automatic cycle uses either an electronic or automatic DRY-MISER® control that senses the moisture in the load and shuts off the dryer when the selected dryness is reached.

The Cycle Control knob does not move until the load is almost dry. After the cool-down, the knob automatically turns to an Off area and tumbling stops.

- If the load is drier than you like, select a setting closer to **Less Dry** the next time you dry a similar load.
- If the load is not as dry as you like, complete drying using a Timed cycle. Select a setting closer to **Very Dry** the next time you dry a similar load.

Drying time with an Automatic cycle varies according to the type of fabric, size of load, and dryness setting. Your model may not have all heat settings listed. Some general guidelines are:

- Use a high heat setting for drying heavyweight items, such as towels and work clothes.
- Use a medium heat setting for drying medium-weight items, such as sheets, underwear, permanent press clothes, and some knits.
- Use a low or extra low heat setting for drying lightweight items such as lingerie, blouses, dresses, and some knits.

NOTE: If you have any questions about drying temperatures for various loads, refer to care label directions.

CYCLE DESCRIPTIONS (CONT.)

Timed cycle(s)

Use a Timed drying cycle to complete drying if some items are damp after the Automatic cycle. A Timed drying cycle is also useful for:

- Heavyweight and bulky items, such as bed spreads and work clothes, and large loads that require a long drying time. Set your dryer to a heat setting that matches the care label directions.

- Lightweight items, such as lingerie, blouses, and knits that require a short drying time. Set your dryer for a low or extra low heat.
- Drying time and temperature will depend on your dryer model.

Fluff Air cycle (on some models)

Use the unheated Fluff Air cycle for items that require drying without heat. For examples of items that require air drying, see the “Fluff Air cycle” later in this section.

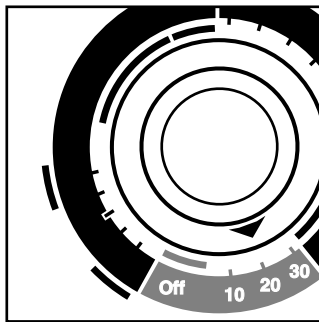

NOTE: If your model does not have the Fluff Air cycle, line dry heat-sensitive items.

Heavy Dry cycle (on some models)

Use the Heavy Dry cycle to dry large items or items that are thicker or heavier than a regular load (such as heavy cotton bath towels or robes.) Set your Cycle Control knob to Heavy Dry and your Temperature selector to High heat.

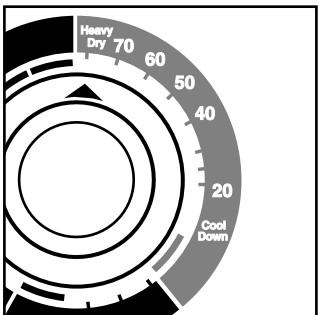

Damp Dry feature (on some models)

Use the Damp Dry feature in the Timed cycle to dry items to damp level or to dry items that do not require an entire drying cycle. Two examples are heavy cottons, such as jeans, which you do not want to become stiff, or cotton clothes which are easier to press when damp. Set the Temperature selector to High heat.

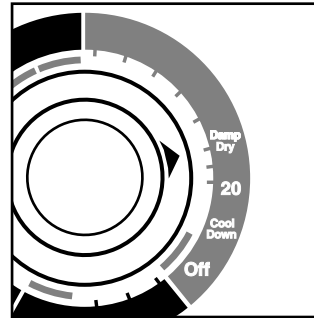

Towels feature (on some models)

When you have large loads of towels to dry, you may want to use the Towels feature in the Automatic cycle. The Towels setting allows for more drying time and automatically shuts off the dryer when the selected dryness is reached. You can also use the Towels feature for extra heavy items such as mattress pads and quilts. Set your dryer to a heat setting that matches the care label directions.

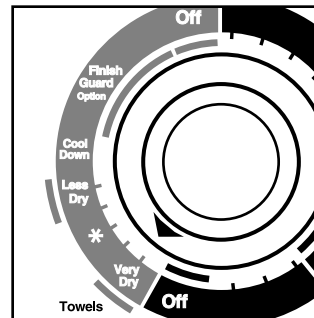

TUMBLE PRESS® feature (on some models)

The TUMBLE PRESS feature in the Timed cycle removes wrinkles from clothes that have been packed in a suitcase or closet, or from items not removed from the dryer at the end of a cycle. As soon as the dryer stops, fold or put the items on hangers. Set the Temperature selector to Medium or Low heat.

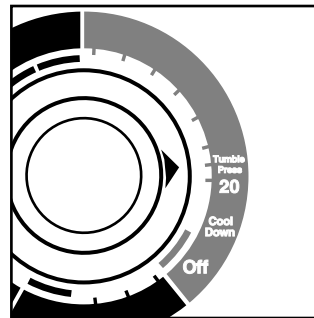

continued on next page

CYCLE DESCRIPTIONS (CONT.)

FINISH GUARD® feature (on some models)

When you are unable to remove a load from the dryer as soon as it stops, wrinkles can form. The FINISH GUARD feature periodically tumbles, rearranges, and fluffs the load to avoid wrinkles.

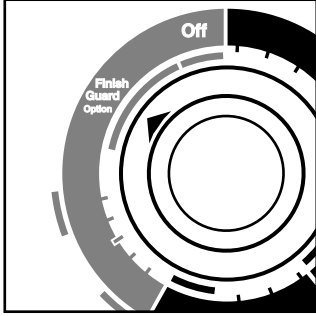

- On some models, this feature is part of the Cycle Control knob.

If you do not open the dryer door within a few minutes after the cycle stops, the FINISH GUARD feature automatically takes over to protect the load.

- On some models, you can turn the FINISH GUARD feature On or Off with a selector. (See Step 4 in “Starting Your Dryer” earlier in this section.)
- A signal will sound every few minutes while FINISH GUARD is running if the Cycle Signal (End of Cycle Signal) feature is set to On. On some models, this signal is fixed and cannot be turned off. The signal and cycle end when you open the dryer door.

FLUFF AIR CYCLE

The chart below includes examples of items that require drying without heat. Use the Fluff Air cycle, or place the items on a line or rack to air dry.

- Line dry bonded or laminated fabrics.
- Always follow care label directions when they are available.

TYPE OF LOAD	FLUFF AIR CYCLE* (minutes)
RUBBER, PLASTIC, HEAT-SENSITIVE FABRICS Foam Rubber – Pillows, padded bras, stuffed toys ● Make sure coverings are securely stitched. ● Shake and fluff pillows by hand several times during the Fluff Air cycle. ● Make sure pillows are completely dry. Foam rubber pillows take a long time to dry. Plastic – Shower curtains, tablecloths Rubber-backed rugs Olefin, Polypropylene, Sheer nylon	20 to 30 20 to 30 40 to 50 10 to 20

* Reset cycle as needed to complete drying.

USING THE DRYING RACK (AVAILABLE AS AN OPTION ON SOME MODELS)

Use the drying rack to machine-dry items you would not necessarily want to tumble dry. The rack gives you concentrated heat for efficient and uniform drying. It also reduces noise when drying heavy items such as tennis shoes.

To order a drying rack, call **1-800-253-1301**, from anywhere in the U.S.A. You will hear a recording. Follow the instructions to place an order.

To use the drying rack:

1. Open dryer door.
2. Slide drying rack over the bottom of the dryer door opening. Push down to secure rack on frame.

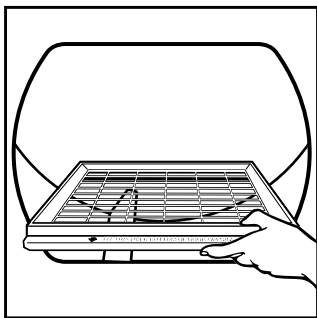

3. Put wet items on top of the rack.

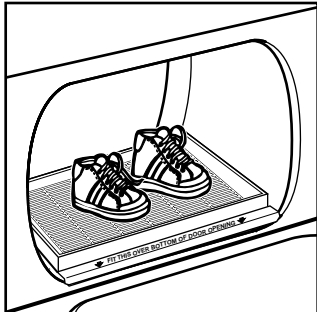

- Leave space between the items so air can reach all surfaces.
- See chart below for suggested cycles and settings for items that might best be rack dried. Drying time will depend on amount of moisture items hold.

NOTE: Make sure nothing hangs over the edge of the rack.

4. Close the door.

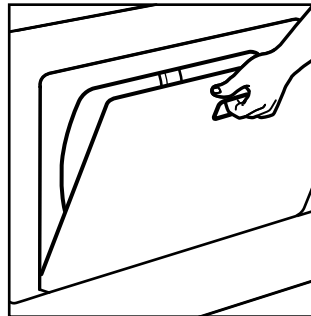

5. Select the Timed drying cycle and temperature, or the Fluff Air cycle.

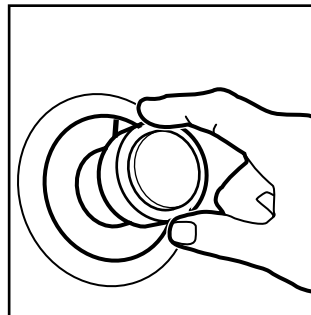

6. Push the Start button.

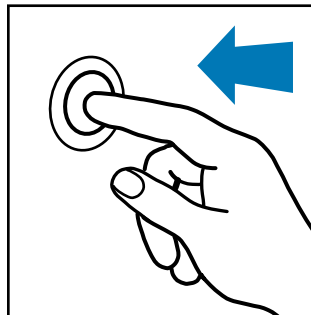

NOTE: The rack must be removed for normal tumbling. Automatic cycles do not work with the drying rack.

RACK DRY	CYCLE	TEMPERATURE	TIME* (minutes)
Wool sweaters (Block to shape and lay flat on the rack)	Timed drying	Low/Ex Low	60
Stuffed toys or pillows (Cotton or polyester fiber filled)	Timed drying	Low	60
Stuffed toys or pillows (Foam rubber filled)	Fluff Air	None; cycle is unheated.	90
Sneakers or canvas shoes	Fluff Air	None; cycle is unheated.	30 to 40

*Reset cycle as needed to complete drying.

CARING FOR YOUR DRYER

Proper care of your dryer can extend its life and help your dryer operate efficiently.

CLEANING THE LINT SCREEN

Every load cleaning

The lint screen is located in the door opening. **Clean it before each load.** A screen blocked by lint can increase drying time.

To clean:

1. Pull the lint screen straight up.

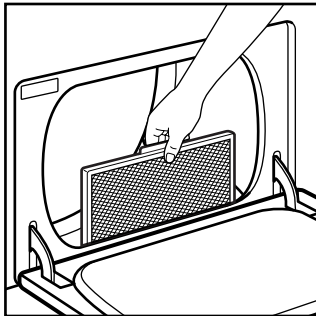

2. Roll lint off the screen with your fingers. Do not rinse or wash screen to remove lint. Wet lint is hard to remove.

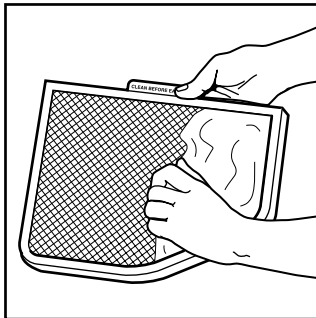

3. Push the lint screen firmly back into place and close the lid.

IMPORTANT:

- Do not run the dryer with the lint screen loose, damaged, blocked, or missing. Doing so can cause overheating and damage to both the dryer and fabrics.
- Some towels made of synthetic fibers and natural fibers (polyester and cotton blends) may shed more lint than other towels, causing your dryer's lint screen to fill up faster. Be sure to remove lint from the lint screen before and after drying new towels.
- If lint falls into chute, double-check exhaust hood and clean out lint if necessary.

As needed cleaning

Laundry detergents and fabric softeners can cause a residue buildup on the lint screen. This buildup can cause longer drying times for your clothes, or cause the dryer to stop before your load is completely dry. You may be able to see this buildup, or the lint may be falling off the screen because it is clogged.

Clean the lint screen with a nylon brush every six months or more frequently if it becomes clogged due to a residue buildup.

Use the following method:

1. Wet both sides of lint screen with hot water.
2. Wet a nylon brush with hot water and liquid detergent; scrub lint screen with the brush to remove residue buildup.

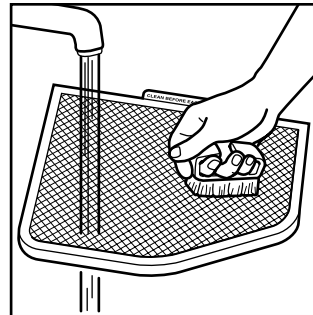

Wet a nylon brush with hot water and liquid detergent; scrub lint screen with the brush to remove residue buildup.

3. Rinse screen with hot water.
4. **Thoroughly** dry lint screen with a clean towel; replace in dryer.

CLEANING THE DRYER INTERIOR

Garments which contain unstable dyes, such as denim blue jeans or brightly colored cotton items, may discolor the dryer interior. These stains are **not** harmful to your dryer and will not stain future loads of clothes. It is helpful to dry unstable dye items inside out to prevent dye transfer.

NOTE: Even after cleaning, these stains may reappear when similar loads are dried.

To clean dryer drum:

1. Make a paste with powdered laundry detergent and very warm water.
2. Apply paste to a soft cloth.

OR

Apply a liquid, non-flammable household cleaner to the stained area and rub with a soft cloth until all excess dye is removed.



3. Wipe drum thoroughly with a damp cloth.
4. Tumble a load of clean cloths or towels to dry drum.

⚠️ WARNING



Explosion Hazard

Use nonflammable cleaner.

Failure to do so can result in death, explosion, or fire.

CHANGING THE DRUM LIGHT

The dryer light automatically turns on inside the dryer drum when you open the door.

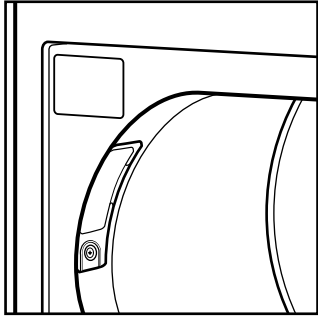

To change drum light:

1. Unplug dryer or disconnect power.
2. Open the dryer door. Remove the screw that holds the lens in place.

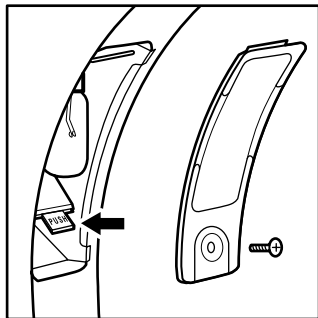

3. Remove the lens by pulling it down and away from drum.
4. Push tab to allow bulb to swing out.

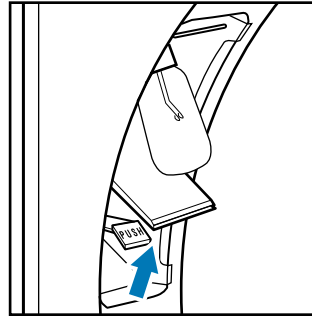

5. Remove the light bulb by turning it counterclockwise.
 6. Install light bulb by turning it clockwise. Replace the bulb with a 25-watt, appliance bulb only.
 7. Push bottom of light and socket assembly in until tab locks.
 8. Place the top of the lens onto the top of the holder. Rotate the bottom of the lens down until it is in place. Replace screw.
- NOTE:** It is very important that the lens is replaced properly.
9. Plug in dryer or reconnect power.

REMOVING ACCUMULATED LINT FROM INSIDE THE DRYER CABINET

Lint can gather inside the dryer and be a fuel for fire. Lint should be removed every 2 years, or more often, depending on dryer usage. Cleaning should be done by a qualified person.

TROUBLESHOOTING

Most laundering problems are easily solved if you understand the cause. Check the following list for **common laundry problems** and the next page for **common dryer problems**. If you need further assistance, see “Requesting Assistance or Service” on page 19.

NOTE: In the following list, the most common laundry problems are listed first.

COMMON LAUNDRY PROBLEMS

Problem ...	Cause ...
Slow drying or clothes still wet	<ul style="list-style-type: none">● Incorrect cycle or temperature setting selected.● Full or clogged lint screen. (See page 14.)● Exhaust vent clogged, restricted, or too long. (See pages 6-7 and Installation Instructions.)● Dryer located in room with temperature below 45° (7°C).● Load too large and bulky to dry quickly.● Drying heavy fabrics (denim, towels) with light fabrics (synthetics, permanent press).● Fabric softener sheet blocking exhaust grill inside dryer drum.
Lint	<ul style="list-style-type: none">● Full lint screen. (See page 14.)● Load not properly sorted.● Overdrying, especially synthetic fabrics that cause lint-attracting static electricity.● Load size too big or heavy.● Tissue or paper left in pockets.● Pilling (surface fuzz caused by normal wear and laundering) attracts lint.
Static electricity	<ul style="list-style-type: none">● Overdrying.● Dryer fabric softener improperly used. See package directions.● Load includes synthetics, synthetic blends, permanent press, and knit fabrics that build up static electricity.
Wrinkling	<ul style="list-style-type: none">● Overloading.● Overdrying, especially permanent press and synthetic fabrics.● Large items balling or rolling up.● Clothes left in dryer at end of cycle.
Shrinking	<ul style="list-style-type: none">● Overdrying.● Fabric or garment is not designed for tumble drying.● Dryer settings incorrect for fabric type.● Care label instructions not followed.
Greasy spots/stains	<ul style="list-style-type: none">● Dryer fabric softener improperly used. Do not add to a warm load.● Drying soiled items.
Color change	<ul style="list-style-type: none">● Drying dark colors with light colors.● Drying colorfast colors with non-colorfast colors.
Garment damage	<ul style="list-style-type: none">● Zippers, snaps, and hooks left open.● Strings and sashes not tied to prevent tangling.● Care label instructions not followed.

COMMON DRYER PROBLEMS

1. Dryer will not start.



Is the dryer door firmly closed?



Are the controls set in an ON position?



Did you firmly push the Start button?



Is the power cord plugged in?

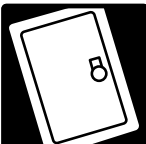

Have you blown a fuse or tripped a circuit breaker? Electric dryers use 2 household fuses or breakers.

2. Lint accumulation in hood or exhaust vent, or extended drying times.



Is lint screen full?



Is exhaust vent or outside exhaust hood clogged with lint? Refer to venting section on pages 6-7.

3. No heat



For gas dryers, is the valve open on the supply line?

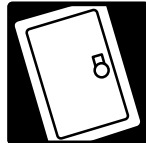

For electric dryers, have you blown a fuse or tripped a circuit breaker? Electric dryers use 2 household fuses or breakers. The drum may be turning but you may not have heat.

4. Noises



If the dryer hasn't been used for awhile, there may be a thumping sound during the first few minutes of operation.

If noises continue, call the Consumer Assistance Center.

5. Odor



When operating a new dryer, the new electric heating element may have an odor.

Are household chemical odors being drawn into dryer? Proper ventilation must be used if painting or staining near the dryer.

NOTE: Store and use paints, varnishes, etc. away from your dryer.

If you still have problems, see "Requesting Assistance or Service" on page 19.

REQUESTING ASSISTANCE OR SERVICE

To avoid unnecessary service calls, please check “Troubleshooting” on pages 17-18. It may save you the cost of a service call. If you still need help, follow the instructions below.

IF YOU NEED ASSISTANCE OR SERVICE

Call the Whirlpool Consumer Assistance Center toll free at 1-800-253-1301. Our consultants are available to assist you.



When calling:

Please know the purchase date, and the complete model and serial number of your appliance (see page 2). This information will help us better respond to your request.

Our consultants provide assistance with:

- Features and specifications on our full line of appliances
- Installation information
- Use and maintenance procedures

- Accessory and repair parts sales
- Specialized customer assistance (Spanish speaking, hearing impaired, limited vision, etc.)
- Referrals to local dealers, service companies, and repair parts distributors

Whirlpool service technicians are trained to fulfill the product warranty and provide after-warranty service, anywhere in the United States.

To locate the authorized Whirlpool service company in your area, you can also look in your telephone directory Yellow Pages.

IF YOU NEED REPLACEMENT PARTS

If you need to order replacement parts, we recommend that you only use FSP® factory authorized parts. FSP replacement parts will fit right and work right, because they are made to the same exacting specifications used to build every new WHIRLPOOL® appliance.

To locate FSP replacement parts in your area, call our Consumer Assistance Center telephone number or your nearest authorized service center.

FOR FURTHER ASSISTANCE

If you need further assistance, you can write to Whirlpool with any questions or concerns at:

Whirlpool Brand Home Appliances
Consumer Assistance Center
c/o Correspondence Dept.
2000 North M-63
Benton Harbor, MI 49022-2692

Please include a daytime phone number in your correspondence.

INDEX

This index is alphabetical. Look for the word or phrase you are interested in, then look for the page number.

TOPIC	PAGE	TOPIC	PAGE
ASSISTANCE	19	LINT	
AUTOMATIC CYCLES	10	Removal	14,16,17
CARE/CLEANING		Screen	14
Dryer interior	15	LOADING	10
Lint screen	14	RACK DRY	13
CHOOSING LOAD SIZES	8-9	SELECTING CYCLE/SETTING	9-12
CYCLES	10-12	SERVICE	19
CYCLE SIGNAL	9	START BUTTON	8
DRUM LIGHT	16	TEMPERATURE SELECTOR	8-12
DRYER		TIMED DRYING	10
Features	5	TOWELS	11
Restarting	9	TROUBLESHOOTING	
Safety	3-4	Dryer problems	18
Starting	8	Laundry problems	17
Stopping	9	TUMBLE PRESS®	11
DRYING		VENTING	6-7
Cycles	10-12	WARRANTY	24
Rack	13		
FINISH GUARD®	8,12		
FLUFF AIR	12		
LINE DRYING	12		

WARRANTY

WHIRLPOOL® DRYER

LENGTH OF WARRANTY	WHIRLPOOL WILL PAY FOR
FULL ONE-YEAR WARRANTY FROM DATE OF PURCHASE	FSP® replacement parts and repair labor to correct defects in materials or workmanship. Service must be provided by an authorized Whirlpool service company.
WHIRLPOOL WILL NOT PAY FOR	
<p>A. Service calls to:</p> <ol style="list-style-type: none"> 1. Correct the installation of your dryer, including venting. Heavy four-inch metal exhaust vent must be used. Refer to the “Checking Your Vent” section of this manual and your Installation Instructions. 2. Instruct you how to use your dryer. 3. Replace house fuses or correct house wiring or plumbing. 4. Replace light bulbs. <p>B. Repairs when your dryer is used in other than normal, single-family household use.</p> <p>C. Pickup and delivery. Your dryer is designed to be repaired in the home.</p> <p>D. Damage to your dryer caused by accident, misuse, abuse, fire, flood, acts of God, improper installation (including, but not limited to, venting with plastic or flexible foil), installation not in accordance with local electrical or plumbing codes, or use of products not approved by Whirlpool.</p> <p>E. Repairs to parts or systems resulting from unauthorized modifications made to the appliance.</p>	

9/97

WHIRLPOOL CORPORATION SHALL NOT BE LIABLE FOR INCIDENTAL OR CONSEQUENTIAL DAMAGES.

Some states do not allow the exclusion or limitation of incidental or consequential damages, so this exclusion or limitation may not apply to you. This warranty gives you specific legal rights, and you may also have other rights which vary from state to state.

Outside the United States, a different warranty may also apply. For details, please contact your authorized Whirlpool dealer.

If you need service, first see the “Troubleshooting” section of this book. After checking “Troubleshooting,” additional help is available by checking the “Requesting Assistance or Service” section, or by calling our Consumer Assistance Center telephone number, **1-800-253-1301**, from anywhere in the U.S.A.